

The New Corrugation Pattern for Low Pressure Plate Condensers

Leonid Tovazhnyansky, Petro Kapustenko*, Oleksander. Perevertaylenko,
Olga Arsenyeva, Gennadiy Khavin¹

Centre for Energy Saving Process Integration, National Technical University “Kharkov
Polytechnic Institute”, 21 Frunze st. Kharkiv, 61002, Ukraine

¹AO “Sodrugestvo-T”, Krasnoznamenny per. 2 off. 19, Kharkiv, 61002, Ukraine
kap@kpi.kharkov.ua

Low pressure and especially vacuum vapours condensation processes are widely used in different industries such as power generation, chemical, biochemical, pharmaceutical, food etc. Plate Heat Exchangers (PHEs) are one of the modern efficient types of heat transfer equipment, but their usage as condensers for low pressure vapour is limited mostly because of relatively high pressure drop of condensing media. To overcome this obstacle the new principle of plate corrugation for low pressure plate-and-frame condensers is proposed. The basic trends on developments of corrugated patterns for low pressure plate condensers were investigated. The principle of channels with variable geometry was selected for new corrugated pattern development. The proposed plate for condenser has the heat transfer area that consists of several corrugated sections along its length. Shape and dimensions of ridges and valleys of corrugations are variable. The corrugations are inclined to plate vertical axis so the ridges of two adjacent plate corrugations are in contact. The channel formed by such plates has the variable cross-section area. The experimental study of heat transfer and pressure drop for channels of such pattern was carried out. The dependencies for film heat transfer and pressure drop were obtained for each channel part formed with adjacent sections of the plates. The obtained results were compared with those for plates which are conventionally used. The advantages of proposed corrugation are discussed. The calculation methods based on obtained results were developed for single-phase flows heat exchange and for condensation of pure vacuum vapours. The recommendations on plate surface synthesis are presented.

1. Introduction

Low pressure and especially vacuum vapours condensation processes are widely used in different industries such as power generation, chemical, biochemical, pharmaceutical, food etc. Plate Heat Exchangers (PHEs) are one of the modern efficient types of heat transfer equipment. The principles of their design are sufficiently well described in literature, see e.g. Wang et al. (2007) and Arsenyeva et al. (2009). But their usage as condensers under low pressure is one of the most complicated areas. It is limited mostly

because of relatively high pressure drop of condensing media. The influence of pressure losses on PHE performance as condensers was discussed by Bobbili and Sunden (2009). The importance of the plate corrugation shape on thermal and hydraulic performance of PHEs is established fact. The most recent attempts to generalise correlations for pressure drop and heat transfer in PHE channels were made by Dović et al. (2009), as also Khan et al. (2010). Although the accuracy of proposed formulas is limited, the results permit to make the conclusion that we can adjust the hydraulic resistance of PHEs by application of plates, which form the channels with different cross-section area (and corrugation) along the plate's length. The present paper describes the experimental and theoretical study of processes in such the channels.

2. Experimental part

For experimental study four plates with different form of corrugation along their length were stamped from stainless steel AISI 304. The thickness of metal sheet is 1mm. The geometrical parameters of plates are presented at Figure 1. The plate along its length consists of four sections with the same triangular corrugation inside them. The corrugation parameters are: the corrugation pitch is 27 mm, the height is 7.5 mm, the angle of corrugation inclination to plate vertical axis is 45°. The difference of the corrugated area by sections is determined by the flat zones between corrugations. Those zones have specified width: the 1st section – without the flat zones; the 2nd section – the width of the flat zone is equal to 1/6 of the corrugation pitch (4.5 mm); the 3rd section – 1/3 of the corrugation pitch (9 mm); the 4th section – 1/2 of the corrugation pitch (13.5mm).

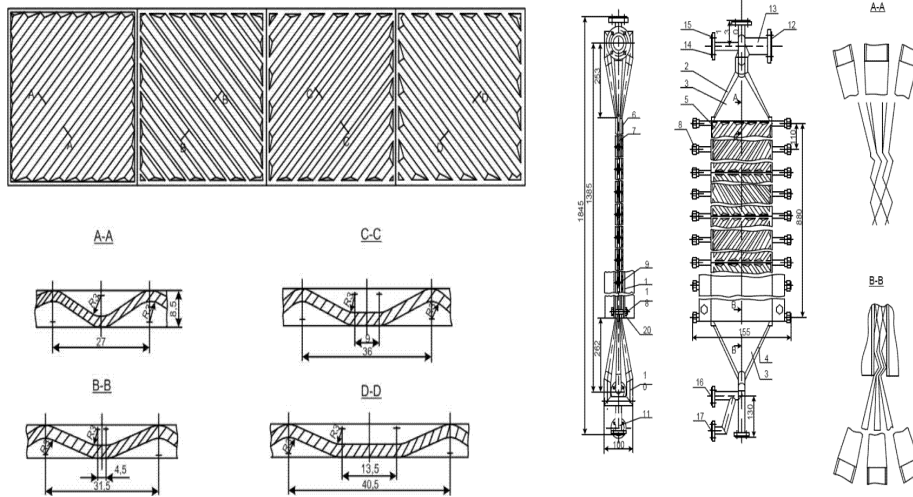

Figure 1: Experimental plate of condenser with variable corrugation along the plate length.

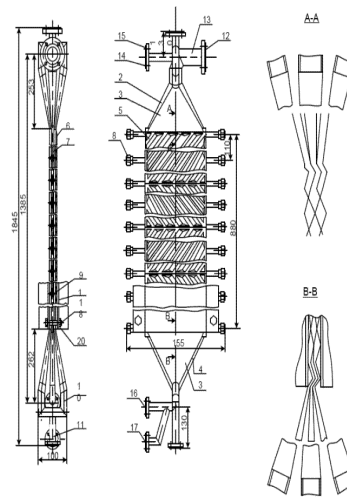

Figure 2: The experimental model of plate condenser.

The experimental model (Fig.2) consisted of four plates welded together to form three inter plate channels. The channel on the vapour side was formed by combination (from up to down) of plates zones: for the first part by contact of 1st and 4th plate's zones, for the second by 2nd and 3rd zones, for the third by 3rd and 2nd zones and for the fourth by 4th and 1st zones. The shape of the formed channels cross-sections is given in Figure 3. Actually for the steam side the channel section decreases along the channel from the beginning to the end, and for the cooling water side it is inversely increases, and there the sum of the cross-section area of two adjacent channels is constant and the same for all four parts. Geometrical characteristics of the channels formed on the all parts of the experimental model are given in Table 1.

The data for hydraulic resistance of channel sections with various corrugation geometry and cross section areas were obtained for the central channel of experimental model for flow of atmospheric air, which flow rate was measured by calibrated rotameter. The pressure drops at different channel sections were measured by U-tube differential manometers filled with water. The obtained results are presented on Fig.4 in a form of dependence of hydraulic resistance coefficient for the unit length of channel $z_i = DP_i \times 2 \times d_{eq} / (r \times w^2 \times L_i)$ from Reynolds number $Re = w \times d_{eq} / \nu$. Here

DP_i - pressure drop on channel section; d_{eq} - equivalent diameter; w - flow velocity; L_i - length of the section; r, ν - flow density and cinematic viscosity, respectively.

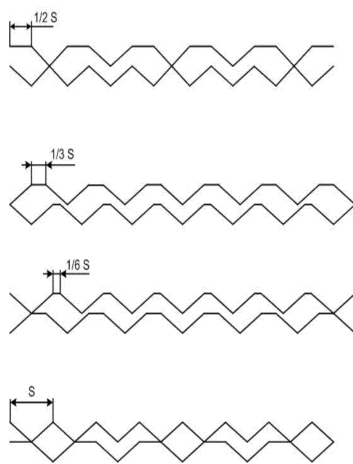

Figure 3: The shapes of the formed channel sections

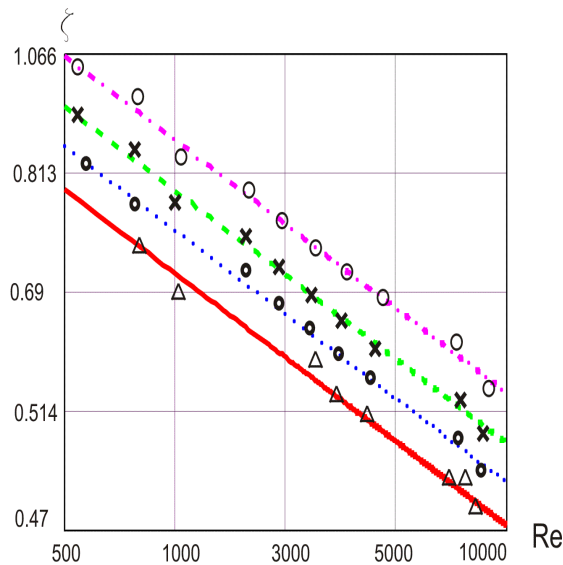

Figure 4: Experimental data for hydraulic resistance of channel sections

The correlations for hydraulic resistance coefficient of the channel length unit are presented in the following form:

$$x = B \times \text{Re}^{-m}. \quad (1)$$

Table 1: Geometrical parameters of channels on the parts of experimental model

Part №	d_{eq}, m	f_{ch}, m^2	L_i, m	f_{pl}, m^2
1	0.01648	0.00219	0.223	0.1198
2	0.01491	0.00198	0.223	0.1198
3	0.01338	0.00177	0.223	0.1198
4	0.01177	0.00156	0.223	0.1198

Table 2: Coefficients in correlations for the channel sections

Coefficient	Section number			
	1	2	3	4
B	2.25	2.486	2.725	3.066
m	0.17	0.17	0.17	0.17
A	0.121	0.124	0.129	0.135

3. Mathematical modelling

As it was shown by Tovazhnyansky and Kapustenko (1984), in channels of plate heat exchangers the modified analogy of heat and momentum transfer holds true. It allows calculate coefficients in correlations for heat transfer film coefficients using formula presented in cited article.

$$Nu = A \text{Re}^{0.73} \text{Pr}^{0.43} (\text{Pr} / \text{Pr}_w)^{0.25} \quad (2)$$

where Pr and Pr_w – the heat carrier Prandtl number and heat carrier Prandtl number, calculated for plate wall temperature correspondingly. The values of coefficients A for each channel section presented in Table 2.

Having correlations for film heat transfer coefficients and hydraulic resistance in single phase flow, we can estimate heat transfer and hydraulic resistance in two phase flow of condensing steam and condensate. For this purpose the formulas recommended in cited above paper.

To calculate plate condenser with accounting for the change of all process parameters it is necessary to use one dimensional mathematical model, as it was shown by Tovazhnyansky et al (2004). Using presented in this paper mathematical model, modified for channel with changing along its length geometrical characteristics, we have developed algorithm and software for calculation of plate condensers with variable cross section.

4. Case study

The problem of vacuum steam condensation with initial temperature equal to 60 °C, pressure – 19,917 kPa and flow rate – 0.5 kg/s – has been examined. The steam is condensed by water with inlet temperature 15 °C and outlet temperature 45 °C. The heat

transfer surface area of one plate is 0.48 m^2 , and the heat transfer surface of the whole unit is 47.52 m^2 .

The heat transfer surface of one plate consists of four zones with different corrugation (see Fig.1). In addition, the calculations were performed for channel of constant cross section formed by plates which had the same corrugation along the length with parameters corresponding to corrugation without flat zones.

The developed algorithm and software allows to calculate the distribution of all process parameters along the condenser channels. The results of calculation of film heat transfer coefficients from condensing steam are presented on Fig.5. In channel of variable cross section the local film heat transfer coefficients h_s is decreased at initial parts of the channel compare to channel of constant cross section (dotted line on all Figures).

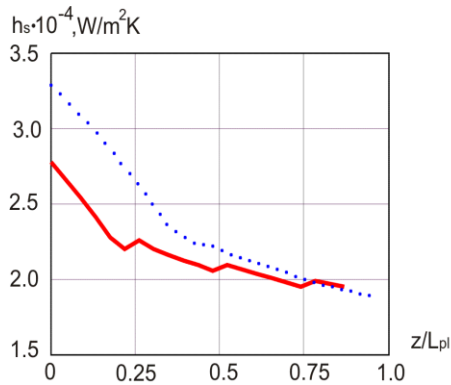

Figure 5: Distribution of local film heat transfer coefficients at steam side along the channel length z .

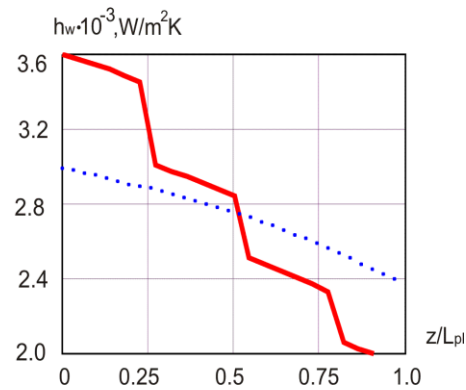

Figure 6: Distribution of local film transfer coefficients at water side along the channel length z .

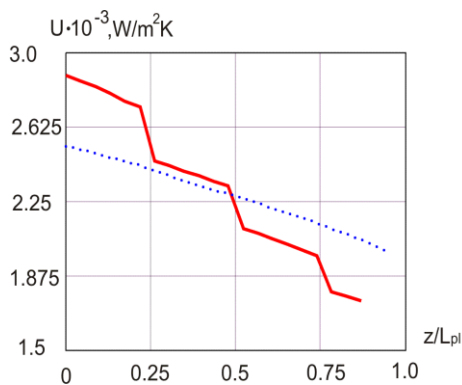

Figure 7: Distribution of local overall heat transfer coefficients along the channel length z .

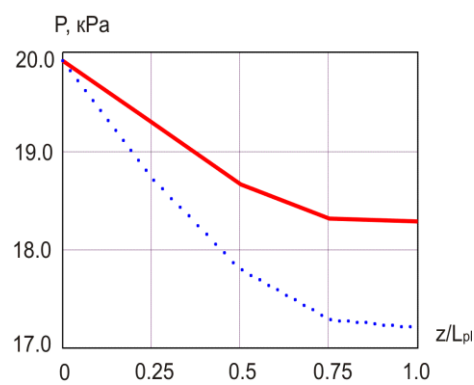

Figure 8: Distribution of pressure in channel of plate condenser along its length z (dotted line for channel of constant cross section).

At the same time film heat transfer coefficient to water (h_w) is considerably increased, as it is shown on Fig.6. Farther on along the channel the picture is changing to opposite. As a result overall heat transfer coefficient (U) also is considerably different from its values in channel of constant cross section (see Fig.7). Such redistribution is leading to intensification of condensation process at channel sections close to steam inlet, where the main part of steam is condensing. The distribution of steam pressure is presented on Fig.8. The overall pressure drop of steam in channel of variable cross section is 1,750 Pa, that is on 4% lower than for the channel of constant cross section, which is equal to 2,900 Pa.

5. Conclusions

The principle of designing plate heat exchangers with variable cross section area along the channel can significantly improve their performance in processes of vapours condensation. It allows reducing considerably (about 40 %) the pressure loss of condensing media. Nevertheless the process of heat transfer at the upper part of the channel show substantial intensification.

The correct calculation of plate condensers with variable cross section area along its length require to employ one dimensional mathematical model and correlations to predict local film heat transfer coefficients and friction factors. Such correlations for investigated forms of plate corrugations are obtained. It shows the way how to obtain such correlations in other similar cases.

References

- Arsenyeva O., Tovazhnyansky L., Kapustenko P., Khavin G., 2009, Mathematical modelling and optimal design of plate-and-frame heat exchangers. *Chemical Engineering Transactions* 18, 791-796.
- Bobbili P.R., Sunden B., 2009, Pressure drop in multi-parallel channels of corrugated plate steam condensers. *Heat Transfer Engineering*, 30 (13), 1024-1032.
- Dović D., Palm B., Švaić S., 2009, Generalized correlations for predicting heat transfer and pressure drop in plate heat exchanger channels of arbitrary geometry. *International Journal of Heat and Mass Transfer* 52 (19-20), 4553-4563.
- Khan T.S., Khan M.S., Chyu M-C., Ayub Z.H., 2010, Experimental investigation of single phase convective heat transfer coefficient in a corrugated plate heat exchanger for multiple plate configurations. *Applied Thermal Engineering* 30 (8-9), 1058-1065.
- Tovazhnyansky L.L., Kapustenko P.O., 1984, Intensification of heat and mass transfer in channels of plate condensers. *Chemical Engineering Communication*. 31(6), 351-366.
- Tovazhnyansky L.L., Kapustenko P.O., Nagorna O.G., Perevertaylenko O.Y., 2004, The simulation of multicomponent mixtures condensation in plate condensers. *Heat Transfer Engineering* 25(5), 16-22.
- Wang L., Sunden B, Manglik R.M., 2007, PHEs. Design, Applications and Performance. WIT Press, Southampton, UK